

## Building Vibration Isolation Systems

Vibration control for buildings and structures

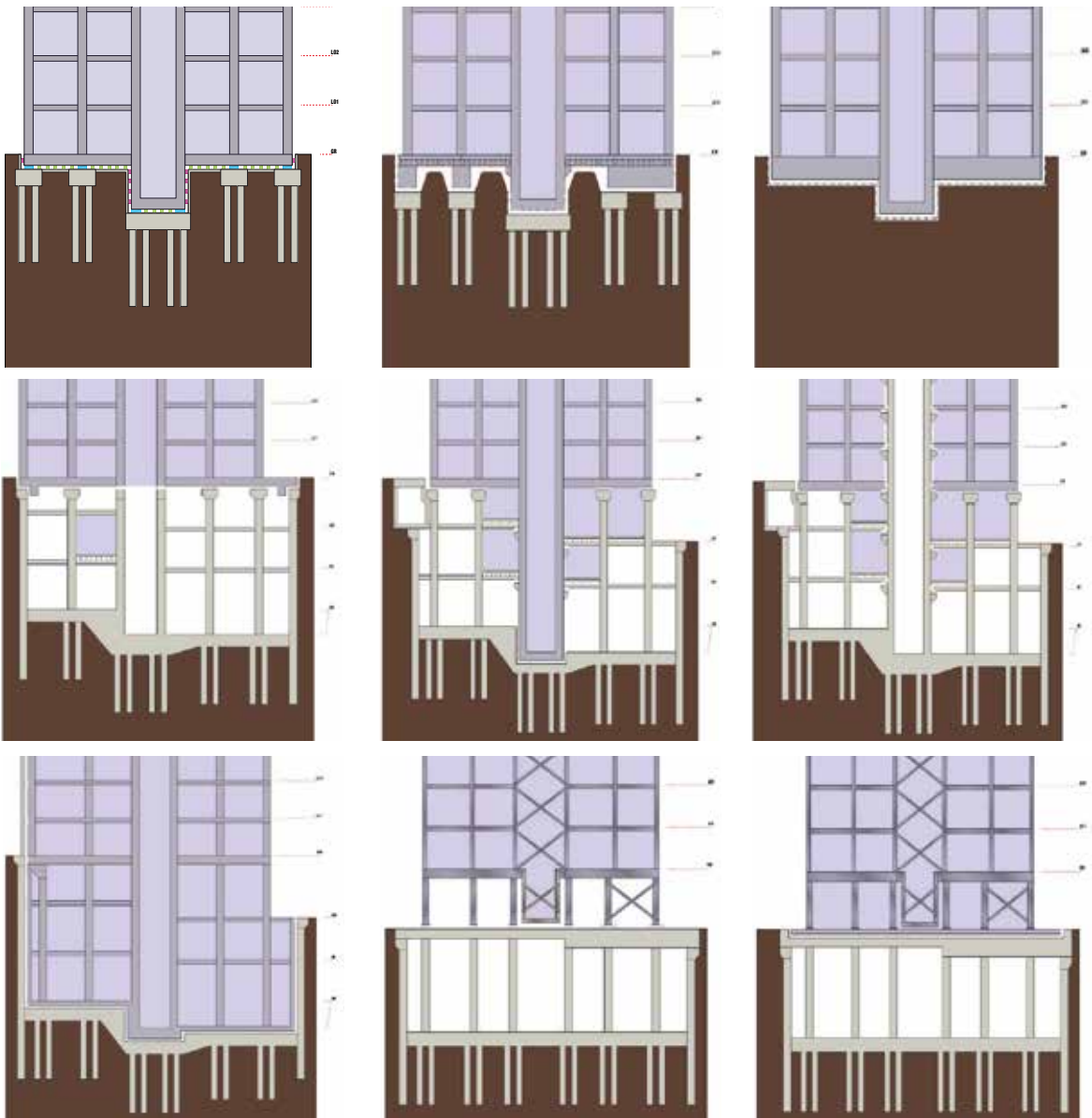

# Introduction

## 1.1 Building Vibration Isolation

**Vibration control solutions are used to support buildings and building structures in order to provide protection from low-frequency ground-borne noise and vibration generated from external sources such as underground railways for the entire life of the building.**

Vibration control of buildings and building structures has been practised since the 1960's and is fast becoming more and more common, especially as whole-building isolation schemes, for a number of reasons:

- ▶ Increasing urban densities leading to developments near to rail, transport infrastructure or industrial facilities.
- ▶ Need to maximise value per unit area by creating multifunctional spaces or high value property in confined areas.
- ▶ Tighter legislation.
- ▶ Increasing demand for functionality and quality.
- ▶ Tendency towards lighter, cheaper structures that use less materials.

The underlying principle of building vibration isolation is much the same as the typical "single degree of freedom" vibration isolation concept, where the section to be isolated is decoupled from the source of disturbance using vibration isolators. These isolators are tuned to a natural frequency that is lower than that of the disturbing frequency, where a lower natural frequency of the system offers a higher degree of isolation. Building vibration isolation becomes much more complex, however, as the foundations and the structure are inherently flexible. Buildings therefore comprise multiple dynamic modes and ultimate design needs must consider every element of the building, not just the structural frame.

## 1.2 Contents

Page 3	<b>Farrat Added Value</b>
Page 4	<b>Design Considerations</b>
Page 6	<b>Vertical Support</b>
Page 8	<b>Installation</b>
Page 10	<b>Lateral Restraint</b>
Page 12	<b>Connections to Non-Isolated Elements</b>
Page 14	<b>Design Services</b>
Page 16	<b>Elastomeric Acoustic Bearing Design and EN 1337-3</b>
Page 20	<b>Project Experience</b>
Page 22	<b>Case Studies</b>
Page 28	<b>Additional Farrat Solutions for Construction</b>

## Typical Applications

- |  |                                  |
|--|----------------------------------|
| <b>Protecting Buildings And Structures From:</b> | <b>Building Types Including:</b> |
| ▶ Railway / Tram Lines                           | ▶ Full Building Isolation        |
| ▶ Underground Rail                               | ▶ Concert Halls / Theatres       |
| ▶ Industrial Facilities                          |                                  |
| ▶ Structure-Borne Noise                          |                                  |
| ▶ Testing Facilities                             |                                  |

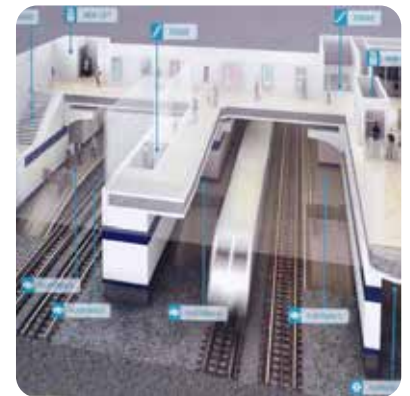

## 1.3 Farrat Added Value

As a proud British manufacturer, Farrat design and manufacture a comprehensive range of ever improving standard and bespoke products; ranging from individual acoustic bearings through to complete building isolation systems (BIS).

**Quality Assurance** - Farrat Isolevel Ltd operates an ISO 9001:2008 approved Quality Assurance System and ISO 14001:2008 Environmental Management Standard, which all Building Vibration Isolation solutions are manufactured under.

Building vibration isolation systems are technically demanding. Farrat are the ideal partner, helping to provide solutions that can be relied upon for the life of the building. A comprehensive range of standard and bespoke structural vibration isolation solutions are available to suit most building types, backed up by cutting edge R&D (part funded by Innovate UK). All this, coupled with Farrat's experienced engineers and design consultancy services, available to work alongside your design and construction team, means that it has never been easier.

### Key features include:

- ▶ Load-carrying capacity up to 17.9MPa (4197kN per bearing) to minimise space
  - Reduced to 10MPa if working to EN 1337-3 stability rules
- ▶ Low and precise natural frequency performance
- ▶ Low vertical deflections
- ▶ Minimal deflection to achieve low natural frequencies
- ▶ Long Service Life\* - 15 year warranty / 60 year design life
- ▶ Ability to eliminate tension within cores and shear walls
- ▶ UK-manufactured products delivering performance, quality, speed & flexibility
- ▶ CE-marked steel fabrications including fail-safes, lateral restraints and shear keys
- ▶ Quality Materials - externally certified elastomeric compounds
- ▶ BIM integration

### Key benefits include:

- ▶ "Hands-on" design and construction support
- ▶ Design consultancy services where Farrat can work with the design team (Architect, Structural Engineer, Acoustic Consultant etc.) to effectively incorporate the BIS into the building to create a coordinated and "construction ready" design \*\*
- ▶ CPD-Certified Lunchtime Seminar

Additional Resources:

\*Farrat's Technical Paper on the Long Term Performance of Natural Rubber Bearings

\*\*ICSV24 Conference Technical Paper

- ▶ Education Facilities
- ▶ Residential / Offices
- ▶ TV Recording Studios
- ▶ Laboratories & Test Facilities

### Protecting Machinery & Sensitive Equipment

- ▶ Power Presses
- ▶ Gensets
- ▶ Turbines
- ▶ Data Centres
- ▶ Oil / Gas Extraction
- ▶ Centrifuges
- ▶ Anechoic Chambers
- ▶ Medical Imaging / CMM



# Design Considerations

## 2.1 Factors to Consider

Typically, the primary factors to consider when isolating a building or structure are;

- ▶ Steel or concrete frame (e.g. stiffness and mass of the structure, construction tolerances, robustness / disproportionate collapse)
- ▶ Characteristics of isolation system (e.g. deflections, access for inspection, replacement, maintenance)
- ▶ Lateral restraint
- ▶ Isolation line through the building (may lead to complicated connections)
- ▶ Interfaces & connections with:
  - Neighbouring buildings or structures
  - Other floor levels
  - Façade & cladding / retained façades
  - Stair cases, lift shafts & cores
  - Disproportionate collapse measures
  - Waterproofing , insulation & gas membrane
  - Fire protection
  - Services

## Farrat Design Support



Farrat's design principles and products provide an adaptable and flexible way of incorporating vibration control into building structures, with the aim to achieve the best combined system performance of load bearing capacity, structural integrity, vibration control and buildability. The success of a building isolation project is not just reliant on the performance of the isolation bearings but also requires consideration of the entire building design including:

- ▶ Structural modelling to achieve an integrated design between the structure and the isolation bearings
- ▶ Robust structural design to take disproportionate collapse and column effective length into account
- ▶ Effective structural and architectural detailing of all interfaces between isolated and non-isolated elements (may be structural internal fit out or services)
- ▶ A construction methodology that minimises risk, time and cost

## Contractor Support

All Farrat products are designed for maximum performance while at the same time being practical and quick to install. Our aim is to provide a service to the contractor that includes:

- ▶ Guidance on overall building design and construction
- ▶ Delivering the right products to site at the right time
- ▶ Planning and co-ordination with the contractor to ensure products can be unloaded from the delivery wagon and efficiently transported to the work area
- ▶ Clear installation schedules and product labelling to ensure that the correct products are placed in the correct locations
- ▶ Well-thought through installation methodologies that take into account location specific constraints with clear and comprehensive installation instructions / drawings
- ▶ Installation briefings, on-site support and inspections

## 2.3 Farrat BVI System Design Examples

The schematics below are examples of Building Vibration Isolation system designs developed by Farrat.

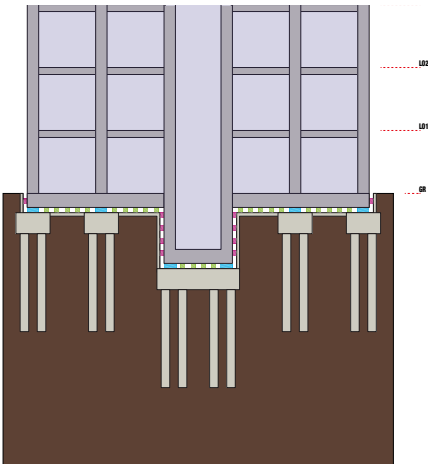

**Fig 2.1 Isolation of Primary Concrete Frame and Cast In-Situ Ground Floor Slab**

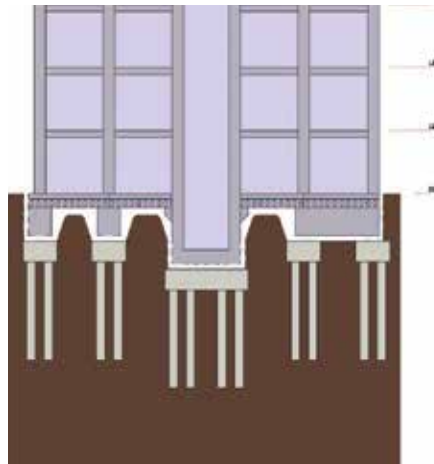

**Fig 2.2 Isolation of Cast In-Situ Ground Beams with Pre-Cast Ground Floor & Steel Frame on Ground Beam Grid**

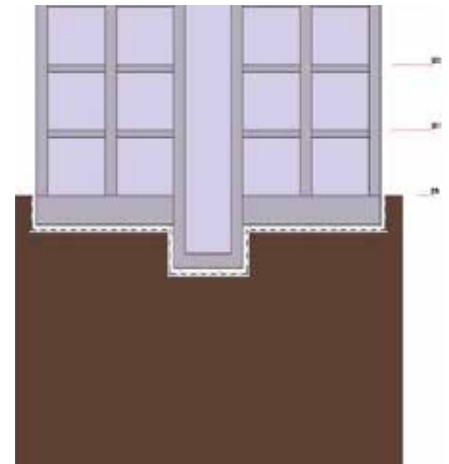

**Fig 2.3 Isolation of Raft Slab with Full Area Isolation Material Installed on Concrete Blinding**

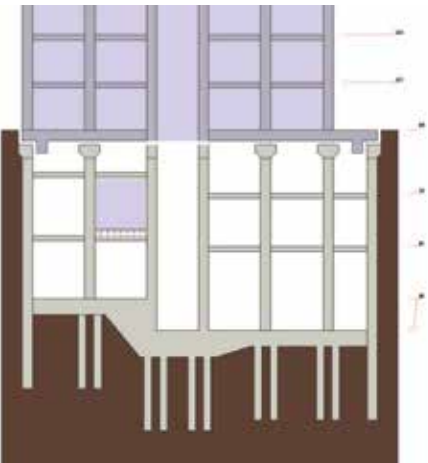

**Fig 2.4 Isolation Under Ground Floor Slab with Isolation Line Passing Through Cores**

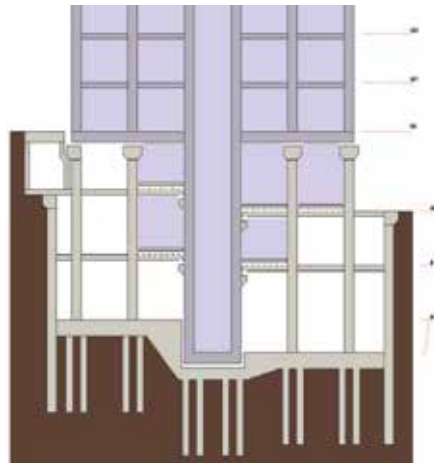

**Fig 2.5 Isolation Under Ground Floor Slab with Cores Isolated at Raft, Requiring Isolation of the Cores**

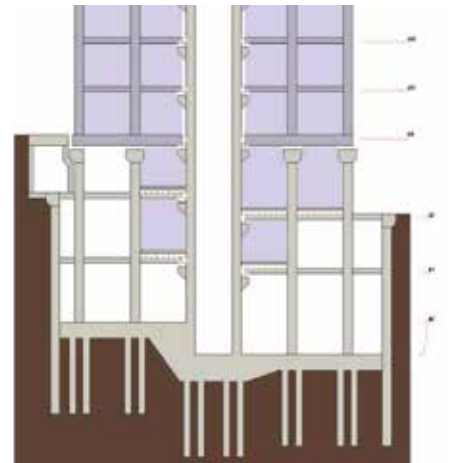

**Fig 2.6 Isolation Under Ground Floor Slab and to Non-Isolated Cores**

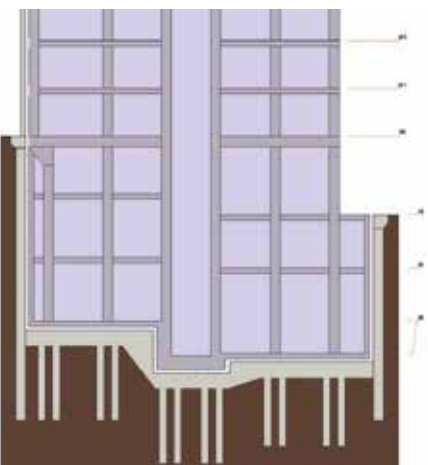

**Fig 2.7 Isolation of Entire Building with Full Basement and Resilient Decoupling From Retained Façade**

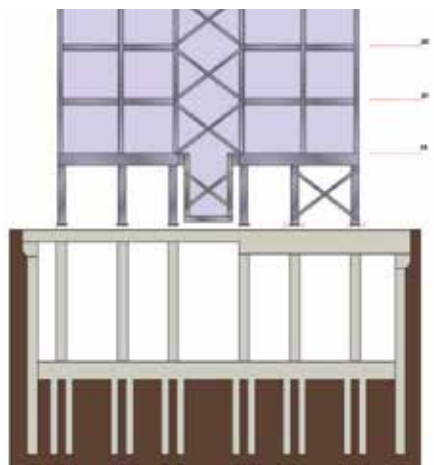

**Fig 2.8 Isolation of Steel Frame;- Lateral Restraint Achieved Through Bracing System & Lifts / Stairs Suspended From Building**

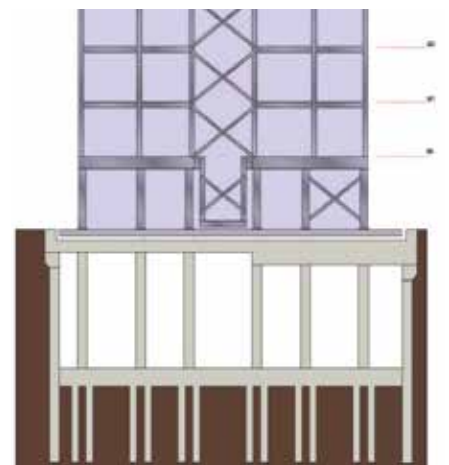

**Fig 2.9 Isolation of Lightweight SFS Steel Frame Floating Floor System**

# Vertical Support

The beginning of any vibration isolation system design is the vertical support element. Farrat have a range of options aimed at providing the right product for the specific application. Once we understand the specifics of the application, let us guide you on selecting the right choice and incorporating it into your design.

## 3.1 Laminated Bearings

Farrat Laminated Natural Rubber (LNR) Bearings are the ideal choice to rely on for optimum performance for the life of the building. Farrat LNR Bearings are the only isolator type whose history reaches back to the origins of structural isolation in the 1950s, with similar products still in operation today.

### 3.1.1 Key Features of Farrat LNR Bearings

- ▶ Load-carrying capacity up to 10 MPa (3,300 kN per bearing)
  - Or up to 17.9 MPa (4,197 kN per bearing) if relaxing EN 1337-3's stability rules
- ▶ Low deflections
  - High capacity and low deflections mean that we can usually eradicate in-service tension from a building design to simplify construction and improve the performance of the building isolation system
- ▶ Dynamic natural frequencies between 6.5 Hz and 22 Hz
- ▶ Creep of  $\leq 2\%$  per decade, which equates to  $\sim 8\%$  additional deflection over the 60 year life of a building. This is considered the lowest possible in the industry
- ▶ Designed and manufactured in accordance with the principles of Eurocode EN 1337-3 (Structural Bearings – Elastomeric Bearings)
- ▶ Manufactured with the highest level of quality control, where each bearing fully inspected and load tested up to its full ULS load capacity and is accompanied by a manufacturing tracker sheet to ensure traceability from the final position in the building right back to the individual batch of rubber compound
- ▶ Every bearing that we produce goes through a rigorous testing programme before it is signed off for use supporting a building. This includes a thorough visual inspection, dimensional tolerance testing to BS EN 1337-3:2005 and compression stiffness testing to BS 6177:1982, all while under maximum factored load conditions (ULS) far exceeding the loads the bearing will see in its lifetime
- ▶ In addition to this, the dynamic and static stiffness of each bearing type we make is tested and certified by an independent third party
- ▶ All bearings are manufactured from natural rubber, which has better resistance to low temperatures and long-term stability due to its crosslinked structure
- ▶ Low filler content to ensure stable and consistent performance under a wide range of amplitudes and frequencies

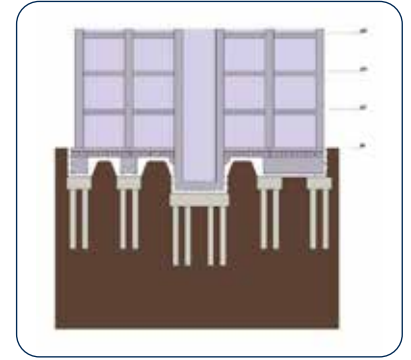

Fig 3.1 Farrat LNR Bearing



Fig 3.2 Farrat LNR Bearings Supporting a Concrete Frame



Fig 3.3 & Fig 3.4 Farrat LNR Bearings Supporting Steel Frames

## 3.2 Full-Area Solutions

**Farrat Verlimber (VR)** is a very-high-performance polyurethane foam that is ideal for full-area solutions where a lower-pressure full-area isolation mat is required.

Farrat offer three standard grades, all capable of natural frequencies down to 8 Hz:

- ▶ VR16 - Max. working pressure: 3 5kN/m<sup>2</sup>
- ▶ VR27 - Max. working pressure: 90 kN/m<sup>2</sup>
- ▶ VR38 - Max. working pressure: 220 kN/m<sup>2</sup>

Full-area solutions can be installed directly onto consolidated hard-core or a simple blinded concrete slab.

As reference, see the case study “Cartwright Gardens” on Pages 26 and 27.

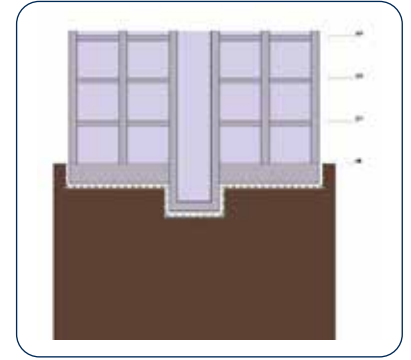

Fig 3.5



Fig 3.6



Fig 3.7

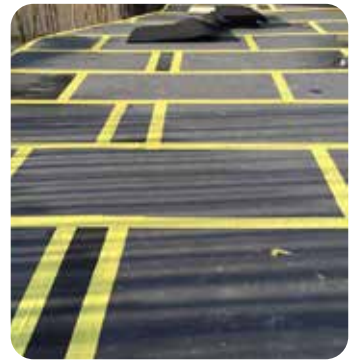

Fig 3.8

Figs 3.5 - 3.8 Farrat Verlimber Full-Area Isolation Materials in Various Building Isolation Projects

## The Right Product for Specific Locations

Farrat offers a range of high-performance Vibration Control, Acoustic & Shock Isolation products to ensure that the right product is used for the specific location. These include:

- ▶ Hybrid H1 and H2 Bearings
- ▶ Farrat ISOMAT
- ▶ Farrat Verlimber
- ▶ Anti-Vibration Materials
- ▶ Anti-Vibration Washers & Bushes

To view our full range of Vibration Control, Acoustic & Shock Isolation (VCAS) solutions, please visit: [www.farrat.com](http://www.farrat.com).

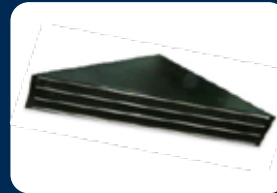

# Installation

A key principle from EN 1337 relates to the installation of structural bearings wherein it states “the plinth shall be level to within a maximum permissible error in rotation from specified position of: 0.3% for bearings supporting a precast or steel structure, 1% for bearings supporting a cast in place structure and generally a maximum deviation of 1 mm per meter is recommended.”

There are various ways of achieving this as outlined below:

## 4.1 Directly onto Concrete or Pre-Prepared Grout Bed

Acoustic bearings can be installed directly onto a concrete support structure or pre-prepared grout bed.



## 4.2 Support Plates with Shims

An economical and generally faster way to achieve the installation requirements is to use a simple steel plate, which can be levelled using shims that can then be grouted in place.

Ideally the plate should have breath holes to allow air to escape during the grouting process.



## 4.3 Levelling Plates

Farrat can offer support plates as Levelling Plates, which incorporate levelling screws to enable faster and more accurate installation.

Steel support plates may be an essential requirement to ensure an even load distribution from the bearing into the reinforced concrete supporting structure, especially for small contact areas such as at the top or bottom of columns.





## 4.4 Fail-Safe Bearing Assemblies

Where fail-saves are required in the design these can be provided with or without levelling screws and can also enable vertical ties and other features as required by the design.

Fail safes allow the entire assembly to be factory assembled, enabling the bearing assembly to be delivered as one unit with lifting eyes for fast off-loading, distribution and installation.

Fabrications can be CE marked and galvanised.

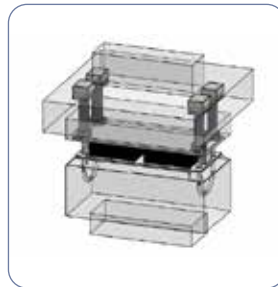
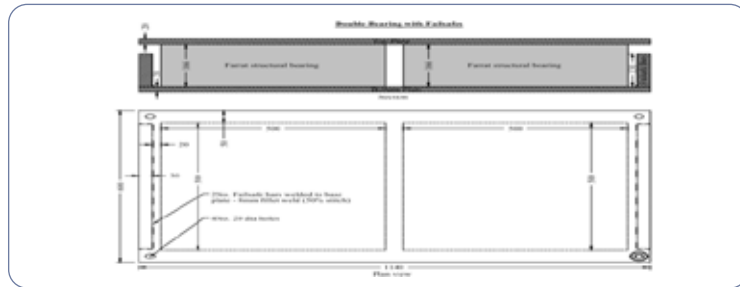

## 4.5 Bespoke Assemblies

The greatest challenge in building isolation systems is not the design of the bearings but how to package all the technical features (required for construction, operation and in case of disproportionate collapse) together. The constraints can vary depending on the project and the specific location although the following factors are generally the key elements to consider:

- ▶ **Lateral restraints** - generally for robustness / disproportionate collapse (typically 75 kN for internal columns and 150 kN for external) and possibly some degree of in-service lateral load component depending on the design and effective length of the column
- ▶ **Load spreading** - to spread the load evenly and efficiently from the column area to the full area of the bearings
- ▶ **Vertical ties** - depending on whether tension is expected or if the number of levels of basement are below the level of the bearings.
- ▶ **Replaceability** - of bearings, lateral restraints or entire assembly

All fabrications are CE marked and galvanised.

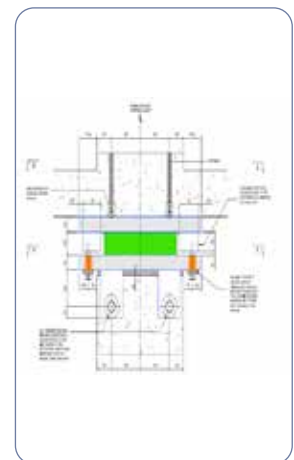
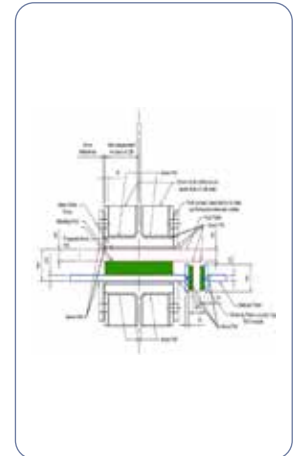

# Lateral Restraint

All buildings will be subject to a degree of lateral loading, typically from wind. The structural design will dictate how that horizontal loading should be resisted, either through stability cores, shear walls or bracing.

There are numerous approaches to lateral restraint where the ideal solution is dependent on a number of factors inherent in the structural frame design. Either way, the building should be designed to avoid excessive lateral restraint as too much will reduce the effectiveness of the vibration isolation system.

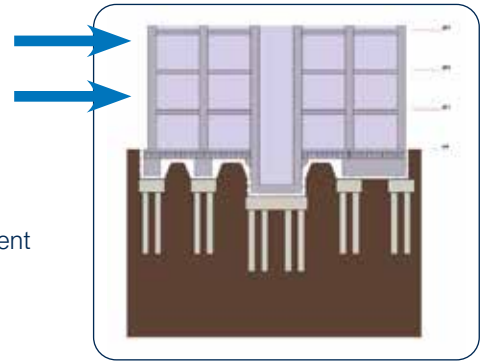

## 5.1 Acoustic Shear Keys

Farrat Acoustic Shear Keys have been specially designed to provide compact, high-capacity vertical support and lateral restraint that can be installed quickly and easily using standard contractor methods.

Combining the vertical support within the lateral restraint provides significant benefits to the structural design and makes for a more-efficient load path through the system. Conversely, the shear keys have been designed to also work with low vertical loading (e.g. when wind unloads one side of a shear wall), which can be a significant advantage over other systems that rely on friction to generate the shear resistance within the isolation material.

Farrat offer a range of sizes up to a maximum standard capacity of 900 kN but higher loads can be accommodated using bespoke designs. All fabrications are CE marked and galvanised and each unit is factory assembled and delivered with certified lifting eyes for easy off loading, distribution and installation.

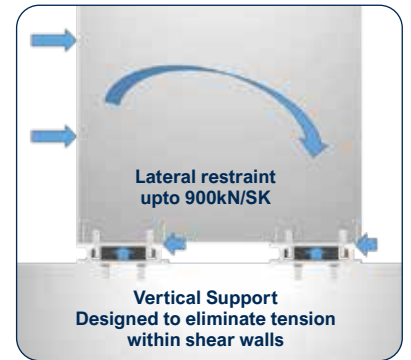

**Fig 5.1 Farrat High Capacity LNR Bearings and Shear Keys Enabling Optimised Structural Design**



**Fig 5.2 Farrat 700 kN Shear Key Units**



**Fig 5.3 Farrat 700 kN Shear Key Unit Being Installed Into Pile Cap**



**Fig 5.4 Farrat 2,000 kN Column Head Shear Key For Offset / Walking Column**

## 5.2 Lateral Bearings

If preferred, to avoid the cost of fabricated shear keys, Farrat can design lateral bearings to be attached to contractor-constructed structural elements.

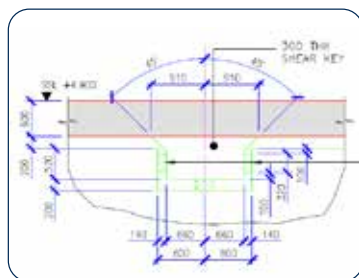

**Fig 5.5 In-Situ Constructed Shear Key**

## 5.3 Isolated Dowels

For low levels of lateral loading, Isolated dowels may be suitable. Farrat supply high-performance isolation caps for standard dowels or rebar that are specially designed to allow vertical deflection as the isolated building deflects.

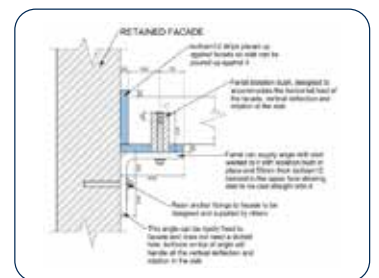

**Fig 5.6 Farrat Isolation Dowels to Resist Light Shear Loadings**

## 5.4 Perimeter / Lateral Isolation

Ideally, an isolated building should be free to move on its isolation system, however in some cases it is inevitable that some or all of its perimeter will be in contact with surrounding, non-isolated / live structures, some of which may exert a lateral (soil) pressure onto the side of the building.

Farrat offer numerous ways of minimising the effects of lateral contact.

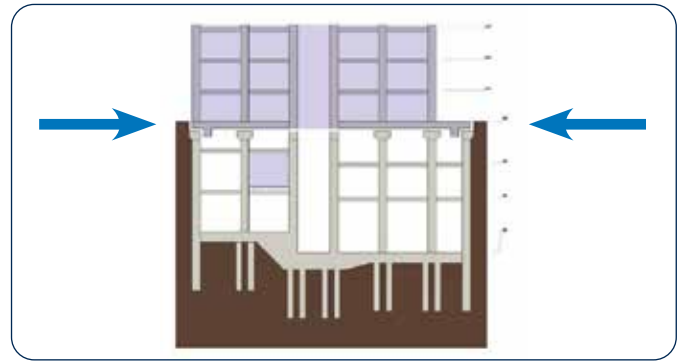

Fig 5.7 Soil Pressure Exerted on Isolated Building

## 5.5 Non-Load Bearing

Where the lateral pressure is minimal, then Farrat ISOFOAM is the ideal choice, having been used in all manner of lateral isolation applications.

A key feature is that concrete can be poured directly up against it, creating a low-stiffness interface without the risk of dirt and debris falling between the isolated and non-isolated elements.

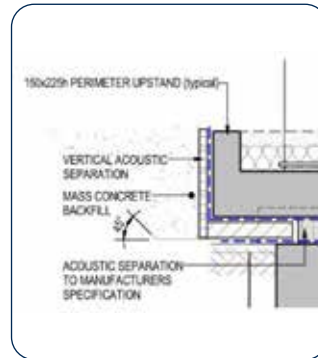

Fig 5.8 ISOFOAM Perimeter Isolation for Backfilled Ground



Fig 5.9 ISOFOAM Perimeter Isolation for Casting Straight Up to Existing Structures

## 5.6 Load Bearing - Tuned with Laminated or Hybrid Bearings Set into Farrat ISOFOAM

This is an economical and precise way of resisting soil pressures over large areas.

The low shear stiffness of the bearings allows shear displacement to accommodate the vertical deflection of the isolated building as it is constructed.

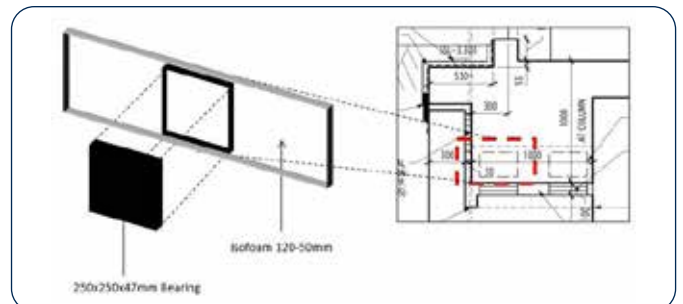

Fig 5.10 ISOFOAM and Bearing Perimeter Restraint System

This system has the additional benefit of being much easier to model than continuous strips. Farrat ISOFOAM strips can be supplied pre-cut to suit the lateral bearings with double sided self-adhesive tape for fast and flexible installation.



Fig 5.11 Self-Adhesive ISOFOAM with Pocket Cut Out to Accommodate Lateral Restraint Bearing



Fig 5.12 Lateral Restraint Bearing Within ISOFOAM Pocket

## 5.7 Load Bearing - Continuous Strip

Farrat Verlimber or ISOMAT can be used where a continuous strip is preferred. Farrat Verlimber Strips can be supplied with double-sided self-adhesive tape for fast and flexible installation.

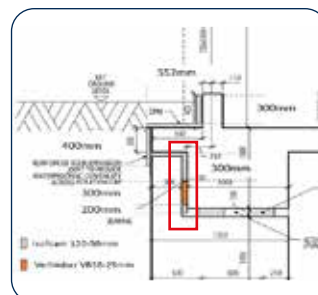

Fig 5.13 High Capacity Lateral Restraint Strip (red)

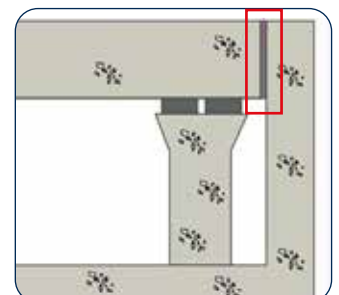

Fig 5.14 VR38 (Red) for Soil Pressure

# Connections to Non-Isolated Elements

For connections to non-isolated elements such as retained façades and cores, Farrat can assist in creating the ideal solution for specific applications.

## 6.1 Floor-Slab to Non-Isolated Connections

Floor slab edge connections can range from simple edge lateral isolation to complex vertical support with varying load and pull or restraint requirements.

Farrat aim to provide a functional (acoustically and structurally) detail that can be constructed easily with minimal risk of poor performance through contractor workmanship.

### Fig 6.2 - 6.4 Examples of Possible Core-To-Floor Slab Connections.

The final design will be dependent on the specific requirements of the connection.



Fig 6.1 Isolated Building with Non-Isolated Core

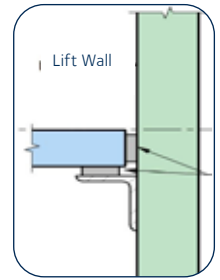

Fig 6.2

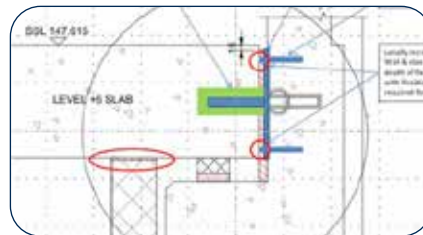

Fig 6.3

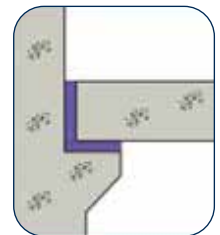

Fig 6.4

## 6.2 Pre-Compressed Bearings For Retained Façades

By using the precise performance characteristics of our LNR Bearings, we can design pre-compression assemblies to preset the bearing to the anticipated load of the retained structure to ensure minimal settlement and the same natural frequency as the rest of the building.

### Fig 6.6 Farrat Pre-Compressed Bearings Under Retained Façade Column



Fig 6.5 Retained Façade



Fig 6.6

## 6.3 Isolation of Non-Structural Elements

Using our range of Anti-Vibration Materials, Washers and Bushes, we can provide solutions for all manner of additional details such as façade, lift mechanisms and internal partition wall wind posts.



Fig 6.5 Retained Façade

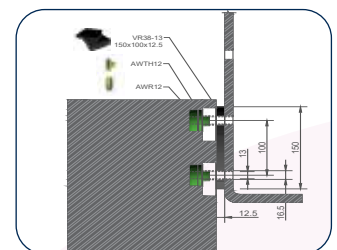

Fig 6.6



Fig 6.9 Farrat VR, ISOMAT and AWTH Acoustic Washers

## 6.4 VFT System

In some designs the primary load of the building is designed to pass through the columns into the primary support acoustic bearings and foundations while still requiring the in-situ ground floor slab to be cast onto the ground in-between.

This poses a challenge as it requires a full-area isolation solution to achieve the same low frequency as the rest of the vibration isolation system with very low pressures.

- ▶ Farrat have developed the VFT system that provides a fast, easy, adaptable and economical method for casting 200 - 300 mm thick isolated ground floor slabs
- ▶ VFT system tiles are supplied in 2 m x 1 m tiles which can be easily cut to size on site
- ▶ We offer a full design service to create dedicated construction drawings to facilitate installation

**Fig 6.11 & 6.12 Example Where VFT is Required & VFT System in Construction**

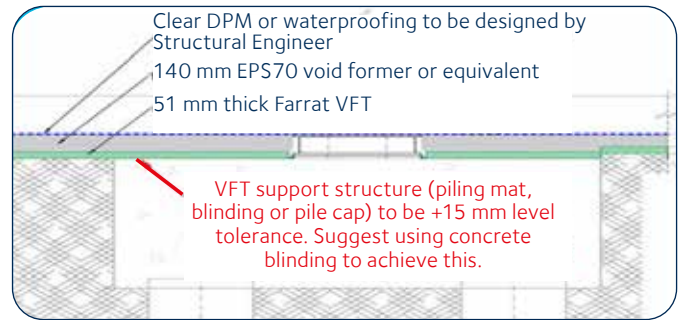

**Fig 6.10 Typical VFT System Detail**

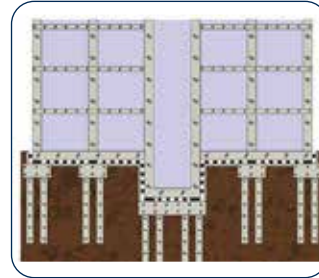

**Fig 6.11**

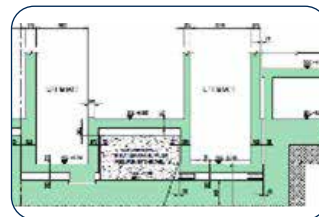

**Fig 6.12**

## 6.5 Floating Floors

Farrat's range of Acoustic Floating Floors can be incorporated into a building isolation strategy either to enable the construction of slabs where access after casting is not possible or for rooms in un-isolated areas of the building.

**Fig 6.13 & 6.14 ISOMAT Floating Floors Used to Construct Complex Cores**



**Fig 6.13**



**Fig 6.14**

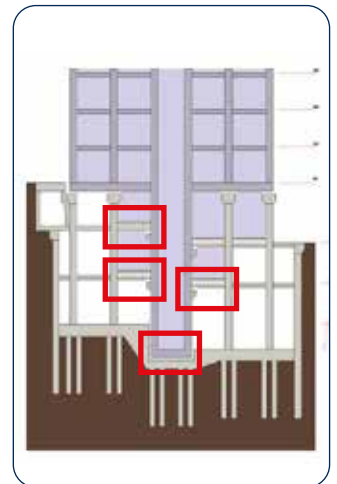
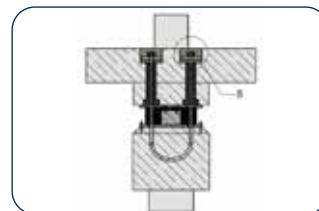

**Fig 6.15 ISOMAT FF Systems Required**

## 6.6 Isolation Details

Farrat offer a range of standard and bespoke solutions to isolate / decouple additional elements of a building that are required to cross the isolation line, e.g. Washers, Bushes and Caps for vertical ties, as shown in the images to the right.

The design intent is to minimise the risk of any bridging occurring, therefore requiring that architectural design details and construction tolerances are considered.



**Fig 6.16 Typical Vertical Tie Design**



**Fig 6.17 Vertical Ties Passing Through Top of Bearing Assembly**



**Fig 6.18 ISOFOAM Bushes Isolating Vertical Ties Passing Through Slab**



**Fig 6.19 Typical Vertical Tie Design**

# Design Services

**With building isolation projects, it is better to incorporate the isolation system into the design as early as possible, however it is our aim to provide a high level of service and value at any stage in the process.**

For all sizes of project, we are able to offer hands-on design support and coordination services, backed up by diverse and extensive practical experience to form a vital link between the Structural Engineer, Architect and Acoustic Consultant. We can assist with feasibility, practicality and design coherency for this critical aspect of the building support structure to make designing, specifying and installing Farrat products efficient and effective.

For smaller projects, we can provide advice, bearing schedules and comment on proposed details. For larger projects we are able to offer a full design consultancy service, becoming an integral member of the Design Team.

Contact our Technical Team for details of spring constants.

## 7.1 Transmissibility Modelling

Constantly evolving research and development is at the heart of everything that we do at Farrat, which is why we take pride in the deep understanding we have of our bespoke elastomeric compound mixtures and the products we create.

At our laboratory facility in Altrincham, Cheshire we have a suite of dynamic and static measurement apparatus, which are able to provide us with detailed performance characteristics of all of our products.

This allows us to offer highly accurate acoustic transmissibility modelling for our entire bearing range. Using load profiles and site-specific vibration survey data provided by our client we can model both the static and dynamic performance of a particular bearing or combination of bearings. The output of our model can be either transmissibility or isolation efficiency from 1/1 octave to single Hertz resolution.

We can also provide load-case-specific compression moduli for input back into the structural model. Through a continued programme of performance monitoring, live site testing and research collaboration with major academic institutions and consulting engineering practices, we constantly refine and improve our model and the library of measured data it is based on.



### Additional Resources:

- ▶ ICSV24 Conference Technical Paper

Download our ICSV24 Conference Technical Paper from our website:  
[www.farrat.com](http://www.farrat.com)

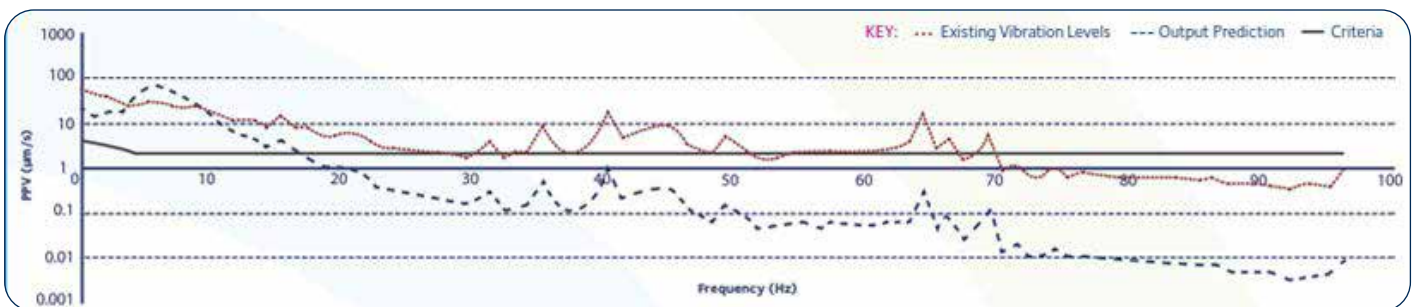

**Fig 7.1 Farrat Acoustic Bearing Transmissibility Model Output**

This advanced and precise knowledge & understanding of our bearing range, means that Farrat bearings can be specified with confidence and expected to perform reliably over the entire lifetime of the building.

## 7.2 Building Isolation System Design Coordination

### 1. Structural Engineer

The Structural Engineer provides vertical loadings for each position in the building based on pin connections within the structural model, ideally in MS Excel form:

- ▶ Loads to be provided as un-factored dead and live load with associated load factors to obtain ultimate factored loading
- ▶ Live loads should include all relevant live load reductions as we want to design for accurate loadings in normal service conditions
- ▶ Allow for real anticipated superimposed loadings rather than simply relying on worst case, e.g. applicable to façade and fit-out finishes
- ▶ Core / shear wall loadings to be initially provided as total load for each core / shear wall
- ▶ Each position to have a reference number that can be cross-referenced to a layout plan

### 2. Project Team (Acoustic Consultant, Structural Engineer and Client)

The project team need to decide on the appropriate amount of live loading that is anticipated for the acoustic dead load / the loading at which the natural frequency performance specified by the Acoustic Consultant should be achieved. This can in general, be summarised as:

- ▶ Concert halls and theatres: Dead load only
- ▶ High-spec office and residential: Dead load + 10–20% live load
- ▶ Low or medium-spec office and residential: Dead Load + 30–40% live load

### 3. Farrat

Farrat design isolation bearings to achieve the specified natural frequency at the given loadings and agreed load conditions and provide an MS Excel Performance Schedule with vertical and horizontal spring constants for the isolating bearings at each position in the building:

- ▶ If done correctly, the loads should settle down after 2-3 iterations
  - If structural changes are made to the design of the building, then it is advised that the analysis model should be re-run with loads re-issued to Farrat to check isolator suitability
- ▶ Once the vertical bearing design is finalised, the Structural Engineer can analyse the effects of horizontal forces (e.g. wind loading) on the structure, making the assumption that the cores and shear walls are resisting all of these forces
  - Farrat can provide shear stiffness data of the main support bearings as well as specific lateral restraint shear keys (see Page 10) that are designed specifically for these situations

### 4. Structural Engineer

The Structural Engineer needs to consider the effective length of the columns to establish whether they need to be restrained:

- ▶ Elastomeric bearings typically have a lateral stiffness of ~0.5%-1% of their vertical stiffness
  - For example if a column is designed with an effective length of less than 2, then the column would be expected to require isolated lateral restraints to replicate the pinned connection joint. Such a lateral restraint will add cost and complexity to the design and will reduce the isolation system's performance as it is introducing additional stiffness into the connection

### 5. Design Team (Structural Engineer, Acoustic Consultant, Architect, M&E Designers, Client and Farrat)

To Design Team must develop the rest of the isolation system together, to ensure the isolation line through the structure is maintained throughout design, detailing, construction and fit-out.

LOCATION REFERENCE		DESIGN LOADS										BEARING FREQUENCY AND TYPE				VERTICAL LOAD PER BEARING				VERTICAL STIFFNESS NATURAL FREQUENCY			VERTICAL STATH DEFLECTIONS AND SPRING STIFFNESS								
SL	Reference	Area	DL	SL	Reduced SLL	LL	Reduced LL	Windload (kN/m²)	Roofload (kN/m²)	Roofload (kN)	ABL Reduced SLL+Wind LL	SLL SLL+Wind LL	M&E SLL SLL+Wind LL	Number of Bearings	Farrat Size/Date	Length	Width	Height	Load @DL	Load @SLL	Load @SLL	Load @SLL	Frequency @DL	Frequency @SLL	Frequency @SLL	Deflection @DL	Static Spring @DL	Dynamic Spring @DL	Static Spring @SLL	Dynamic Spring @SLL	
		M	M	M	M	M	M	M	M	M	M	M	M			mm	mm	mm	kN	kN	kN	kN	Hz	Hz	Hz	mm	M/Non	M/Non	M/Non	M/Non	
1	COL1	COLUMN	2000	200	250	231	69	1			2328	2432	3359	1	1B-50012(10Hz)-3373	500	500	129	2000	2000	2432	3359	9.1	9.2	9.3	6.0	333	6.8	345	7.0	348
2	COL2	COLUMN	1800	757	227	269	81	11			2108	2837	2700	2	1B-50012(10Hz)-3373	500	500	129	900	1054	1419	1350	10.6	10.1	9.4	3.0	299	3.5	302	4.5	313
3	COL3	COLUMN	737	658	197	227	68	9			1902	1631	2316	1	1B-45012(10Hz)-2613	450	450	121	737	1002	1631	2316	10.9	9.3	9.3	2.7	271	3.6	276	5.5	298
4	COL4	COLUMN	429	439	150	144	43	3			622	1075	1930	1	1B-45011(10Hz)-1919	450	450	118	429	622	1075	1930	10.6	9.3	8.0	2.5	172	3.9	184	6.2	172
5	COL5	COLUMN	113	360	48	35	11	4	250		172	312	438	2	1B-25010(10Hz)-286	250	250	101	57	86	156	219	10.3	8.9	7.4	2.3	25	3.8	22	6.8	23
6	COR1	CORE	751	612	104	364	109	6			1044	1733	2491	1	1B-45012(10Hz)-2613	450	450	121	751	1044	1733	2491	10.8	9.8	9.3	2.8	271	3.8	277	5.7	302
7	COR2	CORE	825	318	96	356	107	78		640	1028	1577	2170	1	1B-50011(10Hz)-2638	500	500	118	825	1028	1577	2170	9.8	9.1	8.4	3.2	255	4.1	253	6.0	261
8	COR3	CORE	974	338	101	371	111	84		900	1186	1767	2430	1	1B-45012(10Hz)-2613	450	450	121	974	1186	1767	2430	10.0	9.6	9.3	3.5	275	4.2	282	5.8	304
9	COR4	CORE	1137	487	146	397	119	65	575		1402	2096	2909	1	1B-50012(10Hz)-3373	500	500	129	1137	1402	2096	2909	9.9	9.4	9.1	3.7	304	4.5	312	6.2	336
10	COR5	CORE	690	875	263	311	93	35	450		1046	1971	2695	1	1B-50011(10Hz)-2638	500	500	118	690	1046	1971	2695	10.5	9.1	8.4	2.7	253	4.1	254	7.3	263
TOTAL SLS				17.421										Total No of Bearings		12															

Fig 7.2 Typical Farrat Bearing Performance Schedule

# Elastomeric Acoustic Bearing Design and EN 1337-3

Eurocode 1337-3 is a well-established standard; however, it is primarily focused on bridge bearings, which are designed to be stiff vertically and flexible in shear and rotation, whereas effective acoustic isolation bearings require low vertical stiffness.

BS EN 1337-3 is, however, suitable for the design of elastomeric acoustic vibration bearings in most other respects apart from the thickness of the elastomer layers, for which the standard sets an upper limit of 25 mm (Clause 5.3.2), and the performance equation given in Clause 5.3.3.2 (design strain due to compressive load), which is not justifiable for acoustic bearings, since the “Standard Sizes” given in Table 8.1 are designs for bridge bearings.

## Other significant points of note to be considered by the Designer in relation to the design of Natural Rubber Elastomeric Acoustic Bearings are:

### 1. Shear modulus of the compound

- ▶ BS EN 1337-3 Section 4.3.1.1 states that these should be between 0.7 MPa and 1.15 MPa
- ▶ Farrat’s anti-vibration NR compounds have the following shear moduli:
  - NR44: 0.5 MPa
  - NR50: 0.7 MPa - primary compound used in Farrat Acoustic Laminated Bearings used for building isolation
  - NR62: 1.1 MPa

### 2 Design of Internal Steel Reinforcing Plates

According to BS EN 1337-3, the steel reinforcing plates for primary structure bearings should be “fully covered with elastomer” i.e. contained within and protected by the bearing’s side cover layer of rubber. Section 6.2.4 of the standard states that the minimum distance between the steel reinforcing plate and the edge shall be 4 mm. In Farrat bearings, this distance is 7 mm.



### 3. Elastomer-to-Steel Reinforcing Plate Bond Strength

According to BS EN 1337-3, the reinforcing plates within the bearing should be chemically bonded (during vulcanisation) to the elastomer to prevent any relative movement at the steel elastomer interface.

This is to be stipulated because the best rubber-to-reinforcement bond is obtained by “hot bonding”, i.e., by forming the bond during vulcanisation or by cross-linking the rubber. It involves placing the metal reinforcement plates, already coated with the appropriate bonding agent, in the mould used for vulcanising the bearing, so that they are in intimate contact with the hot, pressurised rubber as the cross links are formed.

Once the rubber network has been cross-linked, it is not able to flow and conform to the shape and surface texture of the reinforcing plates. The idea being that once formed, the bond becomes stronger than the elastomer itself.

In Farrat LNR Bearings, all internal inter-leaf plates are vulcanised to the rubber using high-quality bonding agent and rigid manufacturing processes in a clean environment. Farrat recommends that the Structural Engineer ensures that all inter-leaf plates are bonded through vulcanisation rather than using adhesives to already vulcanised rubber.

### 4. Elastomer Strain

Lower strain not only improves the acoustic performance of the bearings over a wider load range while improving the long-term performance of the bearing, but it also minimises the creep of the bearing.

Low strain is a key principle of Farrat’s building isolation bearing design, so strain at ULS loads is typically up to ~10%. This fits with consistent and predictable dynamic performance, improves longevity and maintains the stability criterion (buckling, translation and rotation) from BS EN 1337-3.



## 5. Horizontal / Shear Stiffness

Acoustic natural rubber bearings have a horizontal stiffness in the region of 0.5-1% of vertical stiffness, so even minor lateral loads need to be restrained to avoid excessive displacements in the structure. Lateral restraints can be incorporated to restrict this lateral displacement; however, they do reduce the effectiveness of the isolation system.

The target is to develop an integrated design between the Structural Engineer and bearing manufacturer, which reduces the cost and complexity of the system, as well as improving its performance by minimising the use of lateral restraints to the quantity and stiffness that is absolutely needed.

## 6. Elastomer Behaviour

A rubber's performance comes from the cross-linked polymer within it. A soft (low-stiffness) rubber, such as Farrat's NR44 and NR50 compounds used in building isolation applications, has the highest proportion of polymer, giving it the highest level of elasticity and longevity because there are more cross links within it to help it recover following a stress strain cycle. Rubbers can be made harder by adding filler (typically carbon black) which has the effect of enabling it to support a higher load / pressure; however, the filler displaces the polymer meaning there are fewer cross links within the rubber, reducing its elasticity and increasing its rate of compression set and creep.

Rubber is virtually incompressible. Unlike corks and foams, when compressed, its density remains the same so when a vertical load is applied to a rubber pad, the vertical force translates into a horizontal force within the rubber, leading to bulging of the unrestrained edges.

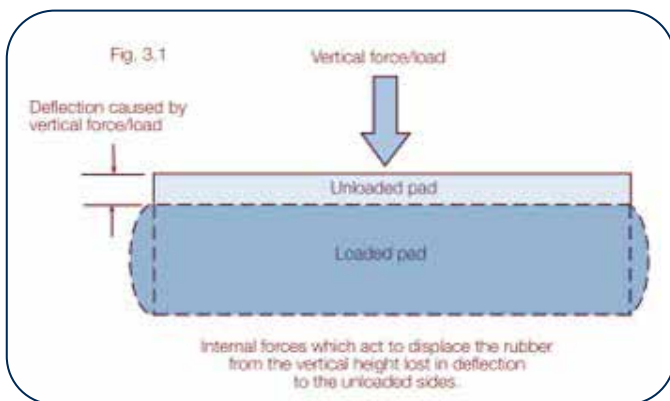

**Fig 8.1 Effect of Vertical Loading on Elastomer Layer Constrained by Laminated (Vulcanised) Steel Plates**



**Fig 8.2 Five-Layer LNR Bearing Under Compression Load**

These internal shear forces can be very high, which is why a vulcanised bond, which should be stronger than the rubber itself, is essential for the long-term performance of the bearing.

This incompressibility means that the shape factor of a rubber bearing / pad, the ratio between the loaded area and the unloaded / unrestrained perimeter is a critical factor in its performance. The larger the bearing, the higher the capacity, but if the rubber layer is too thin (its shape factor is high) then it will demonstrate high non-linearity in both the static and dynamic performance (static stiffness, dynamic stiffness, natural frequency and damping); this is not ideal for acoustic bearings, which should demonstrate consistent spring behaviour over a reasonable load range.

It is important therefore to understand the precise static and dynamic characteristics of a bearing across the entire load range anticipated at the specific location in the building.

Farrat achieves this through continuous research and development, culminating in sophisticated performance prediction algorithms developed using real test data.

## 7. Elastomer deflection

Using low-stiffness compound means that the deflection required to achieve a particular frequency is low. This is an important factor to consider when comparing alternative building isolation systems. Higher deflections can lead to complications in construction such as risks of misalignment in floor thresholds, leading, in some cases, to the need to pre-compress the bearings.

$$\text{For a rubber bearing, Shape Factor} = \frac{\text{Loaded Area}}{\text{Force Free Area}}$$

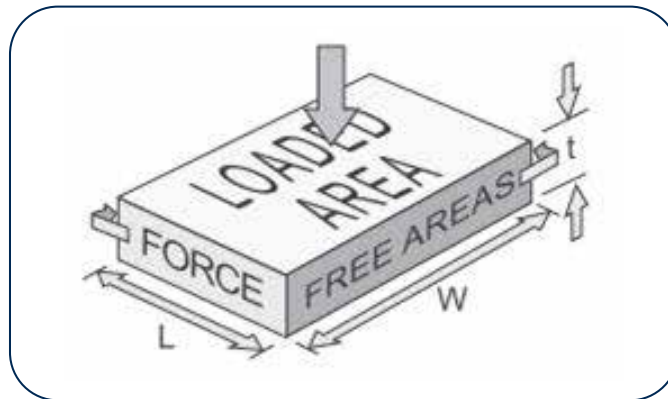

Fig 8.3 Shape Factor Calculation

where:

**L** is the rubber bearing length

**W** is the rubber bearing width

**t** is the rubber bearing thickness

$$\text{Shape Factor} = \frac{LW}{2t(L+W)}$$

The following are examples of performance characteristics of laminated natural rubber bearings:

Figs 8.4 and 8.5 show a natural rubber bearing with shape factor of 2.6 loaded up to a strain of 12%. Note the linear stress strain performance and the consistent, decreasing natural frequency.

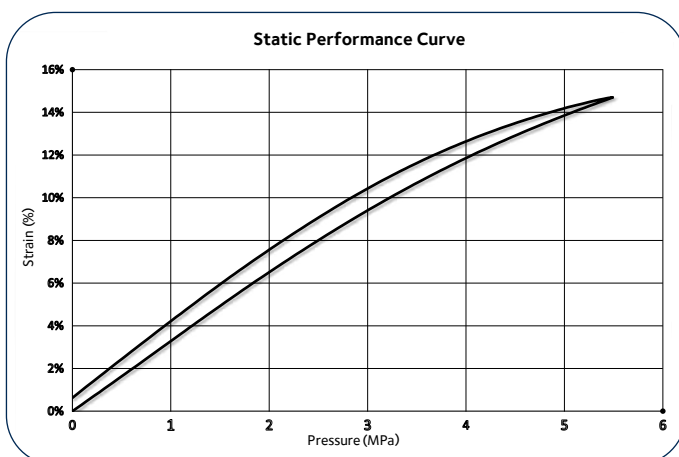

Fig 8.4 Static Performance Curve (12% Strain)

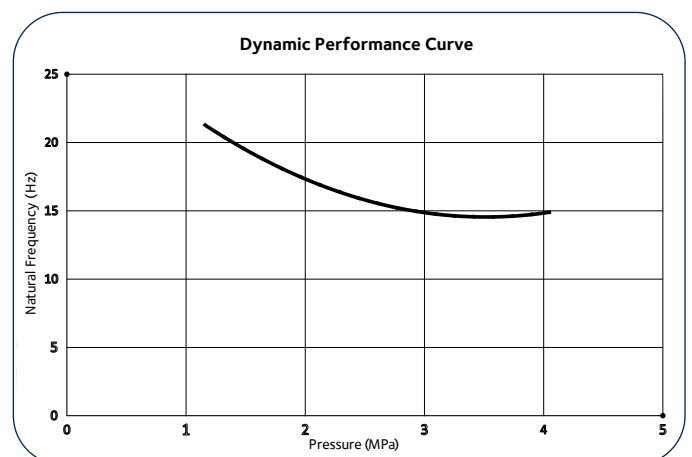
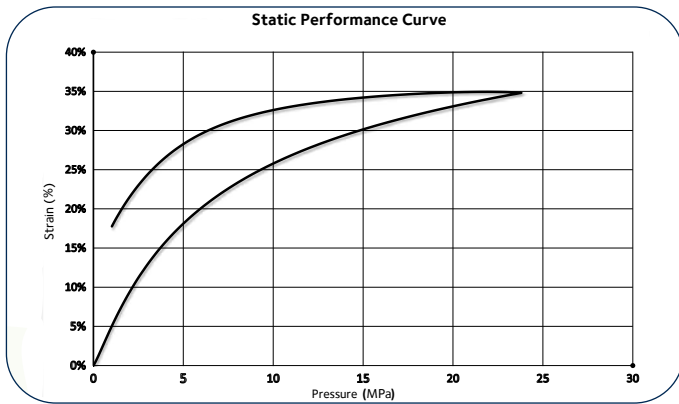
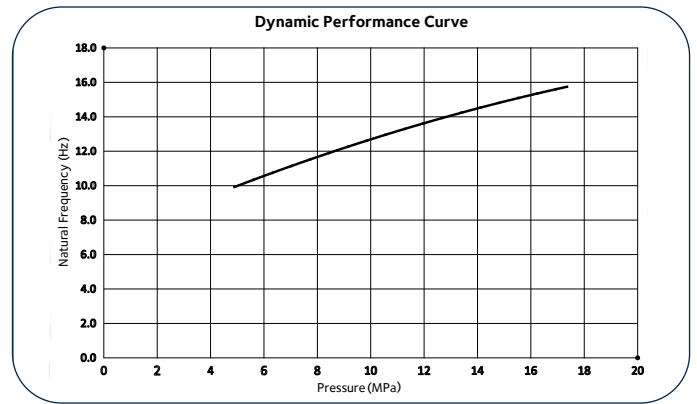

Fig 8.5 Dynamic Performance cCurve (12% Strain)

Figs 8.6 and 8.7 show a natural rubber bearing with a shape factor of 3.1 loaded up to a strain of 36%. Note the rising rate of stiffness and the increasing natural frequency as load increases. Low-stiffness natural rubber, moulded with vulcanised steel inter-leaf plates into low shape factor bearings, offers a consistent, predictable performance across a range of loads, frequencies and amplitudes and can easily be incorporated into structural and dynamic models. Newer materials, such as polyurethane foams typically used in lower-pressure applications, demonstrate quite different behaviour, which is more difficult to characterise for use in structural and dynamic models.

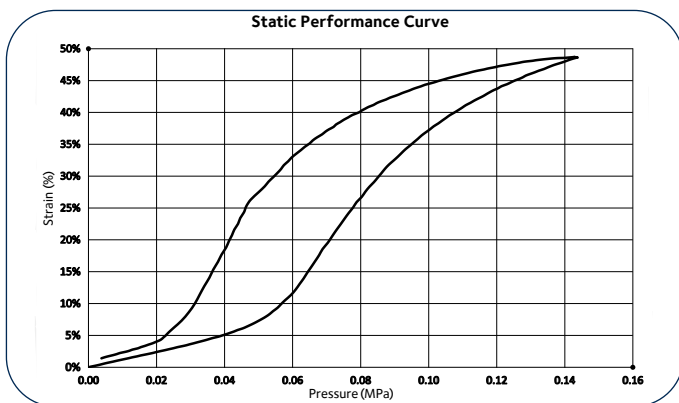

**Fig 8.6 Static Performance Curve (36% Strain)**

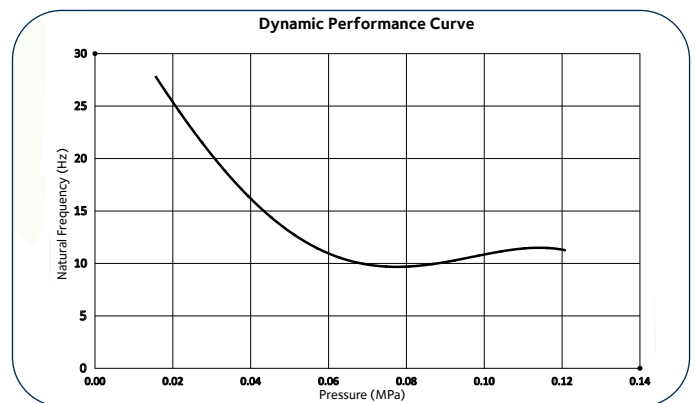

**Fig 8.7 Dynamic Performance Curve (36% Strain)**

Figs 8.8 and 8.9 show Farrat VR27 polyurethane foam isolator with a shape factor of 5 loaded up to a strain of 46%. Note the non-linear behaviour, especially the dramatic change around 10% strain. This is a typical characteristic of such materials, making them more complex to model as part of a structural modelling process. Natural rubber also has the advantage that its dynamic behaviour is highly consistent across a wide range of frequencies and amplitudes.

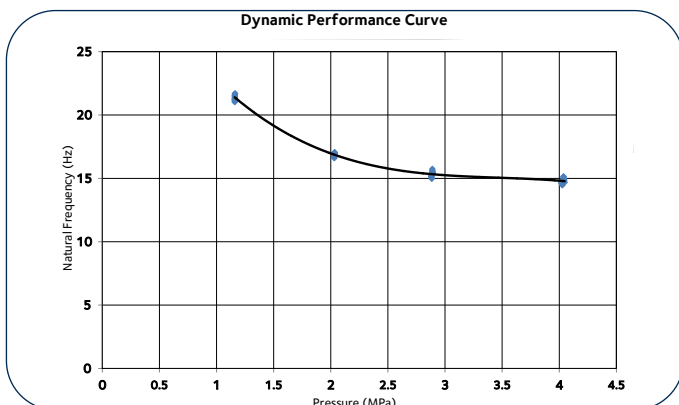

**Fig 8.8 Static Performance Curve (46% Strain)**

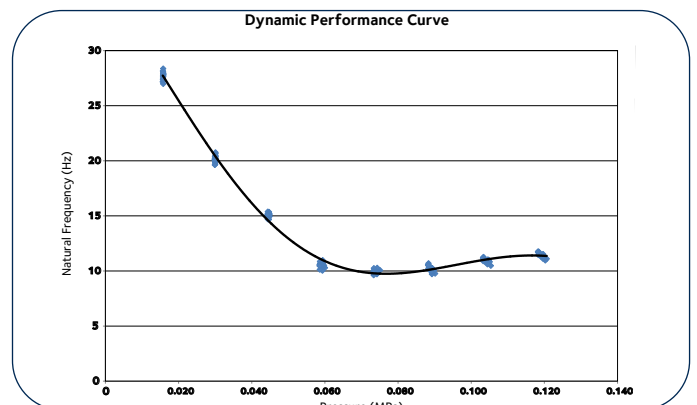

**Fig 8.9 Dynamic Performance Curve (46% Strain)**

Figs 8.10 and 8.11 show dynamic test results from a natural rubber bearing (left) and VR27 polyurethane foam (right) showing the spread of dynamic natural frequency test results when undertaking dynamic cycles at various frequencies (4 Hz, 6.3 Hz, 8 Hz, 10 Hz, 16 Hz, 20 Hz, and 25 Hz) and amplitudes (0.05 mm, 0.005 mm) at each test load.



**Fig 8.10 Static Performance Curve (NR Bearing)**



**Fig 8.11 Dynamic Performance Curve (VR27)**

# Project Experience

Our strength lies in our ability to provide specialist solutions to international projects across a wide range of sectors.

As a proud British manufacturer, Farrat design and manufacture a comprehensive range of ever-improving standard and bespoke products ranging from individual bearings through to complete building isolation systems.

## 9.1 Grosvenor Square, London, UK

Farrat worked intensively with the Design Team (Structural Engineer, Architects, Acoustic Consultant and Contractor) to develop, supply and support the installation of a high-performance 8 Hz building isolation system for a complex building in Grosvenor Square in central London.

The system comprised:

- ▶ 8 Hz acoustic bearings, supplied in fail-safe assemblies with levelling screws
- ▶ Standard and bespoke shear keys
- ▶ Load-bearing Verlimber around capping beam
- ▶ Floor slab isolation vertical bearings and lateral isolation strips
- ▶ Pre-compressed bearings retrofitted into retained façade
- ▶ ISOMAT Acoustic Floating Floors

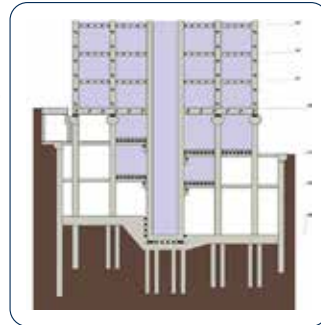

Fig 9.1 Overall Design Concept



Fig 9.2 Vertical Support Bearings



Fig 9.3 Construction of Cores



Fig 9.4 Isolation of Retained Façade

## Range of Applications

### Protecting Buildings And Structures From:

- ▶ Railway / Tram Lines
- ▶ Underground Rail
- ▶ Industrial Facilities
- ▶ Structure-Borne Noise
- ▶ Testing Facilities

### Building Types Including:

- ▶ Full Building Isolation
- ▶ Concert Halls / Theatres



## 9.2 Westfield, White City Extension

A few years on from providing the acoustic isolation system for the multi-screen cinema on the roof of the Westfield White City Shopping Mall, Farrat designed, supplied and supported the installation of 80 bearing assemblies used to isolate a large extension from the London Underground Central Line.

The acoustic bearings, designed to achieve 20 Hz natural frequency under the imposed loads, were supplied in lateral restraint assemblies that were especially designed to withstand lateral, and, in some cases, tension, loads from construction and in service conditions.



**Fig 9.5 Isolation Bearing Assembly With Temporary Construction Restraints**



**Fig 9.6 Large Truss Supported by Farrat Isolation Bearings**



**Fig 9.7 Steel Frame During Construction**

## 9.3 Wembley Central

Built directly on top of Wembley Central mainline rail station, the brief for designing an isolated structure for this project was extremely complex from the very beginning.

A lightweight met-sec structure combined with the shock loading scenario caused when two high-speed trains passed through the station simultaneously, meant that the performance of the vibration isolation system was paramount.

Similar precise consideration was necessary for the structural element of the design, as loads could only be transferred down through the existing station structure through very narrow channels between platforms.

Farrat worked extremely closely with the structural engineers and steel frame contractor to develop a solution that met the vibration criteria of the tenant (a hotel operator) and the onerous structural requirements of Network Rail at the interface of the concrete podium deck with the main steel frame with a very small number of bearing types.



**Fig 9.8 Wembley Central B2**



**Fig 9.9 Typical Braced Column Isolation and Lateral Restraint Detail**



**Fig 9.10 Railway Station Directly Underneath the Building**

- ▶ Education Facilities
- ▶ Residential / Offices
- ▶ TV Recording Studios
- ▶ Laboratories & Test Facilities

### Protecting Machinery & Sensitive Equipment;

- ▶ Power Presses
- ▶ Gensets
- ▶ Turbines
- ▶ Data Centres
- ▶ Oil / Gas Extraction
- ▶ Centrifuges
- ▶ Anechoic Chambers
- ▶ Medical Imaging / CMM



# Case Study

## 10.1 Queen Mary University Graduate Centre

**Main Contractor:** Bouygues UK  
**Consultant:** Bickerdike Allen Partners  
**Structural:** Engineer: BDP

### Challenge

As part of a major redevelopment of one of the UK's largest and leading research-focused higher education institutions, Farrat undertook a £27m project to provide Queen Mary University with a new graduate facility.

The eight-storey facility is constructed with a 750 tonne steel frame and concrete cores, a brick façade and a curtain wall system. It is located in very close proximity to a particularly shallow section of the Central Line, which has train movements every few minutes throughout the day. In the interest of ensuring the best environment for users, the university decided to invest in vibration mitigation measures to eliminate disruptions.

### Solution

Early on (RIBA Stage D), Farrat collaborated with the client's Concept Design Team to provide advice and guidance on the vibration isolation strategy in order to achieve the acoustic requirements set out by the acoustic consultant Bickerdike Allen Partners (BAP) and the client's Structural Engineer. The building was to be an 8-storey steel structure, with no basement, so the ground floor slab was supported directly by the pile caps.

BAP recommended that for buildings on piled foundations, an allowance had to be made to account for the assumed coupling loss that can arise between the ground and the pile of between 4 dB and 7 dB. Amplification factors of 6 dB were included in the calculations to account for the fact that steel frame building elements such as floors and ceilings will tend to amplify vibrations at their fundamental frequency as compared to those present in the building foundations.



Farrat has been very helpful during the design stage and very reliable on product delivery, which was critical for the progress of the project.

**Fabien Roca**  
**Civil Works Manager**  
**Bouyges UK**



## Design

The design incorporates cast-in-situ ground beams with the ground floor slab, constructed using 250 mm precast planks and a 50 mm topping. Farrat worked with BDP to develop and refine the structural and vibration isolation system design.

The process began with BDP issuing all the column and core loads to Farrat as un-factored dead and live loads (un-factored loads are important because the performance of the isolation system is dependent on the typical in-use loadings). Farrat then applied its precise performance prediction tools to design acoustic bearings for each location and returned a Bearing Performance Schedule (BPS) to BDP who converted their pin connection details into springs using the spring constants given in Farrat's BPS.

Although the overall load of the building remained the same, in some locations, this led to some redistribution of loads within the structure. These loads were returned to Farrat to update the BPS and issue back to BDP.

In some locations, the Design Team had to consider horizontal forces resulting from rotation within the ground beams originating from the positioning of the column above and the pile cap below. Initially, this rotation was to be resisted using lateral restraints but BDP and Farrat established that they could overcome the effect through strategic placement of the bearings and, in some cases, splitting a single bearing into two, three or four bearings to give rotational resistance.

The building included seven external V columns which spanned from pile cap level up to the underside of level 2. In these cases, the V shape of the column meant that the vertical load included a horizontal component in line with the V shape which had to be resisted using Acoustic Lateral Restraints.

In the other axis, the columns had to be designed to resist the potential for a vehicle impact.

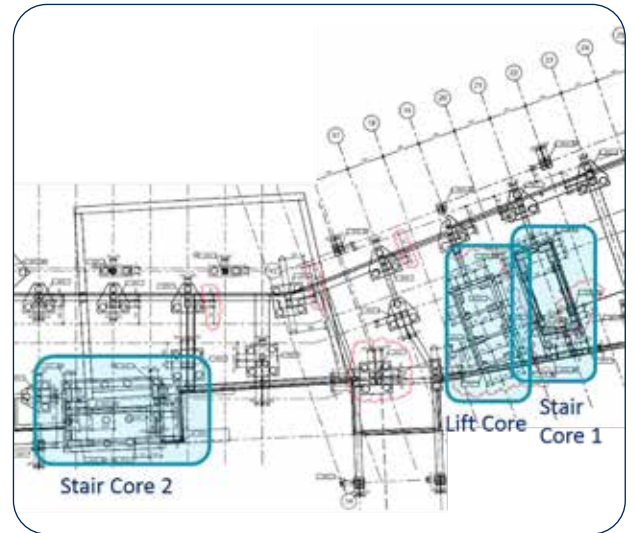

**Fig 10.1 Plan View GA of the Foundations Showing the Position of the Three Stability Cores**

The design of the cores was similar but required a more in-depth analysis to design the bearings in order to eradicate tension and incorporate appropriate lateral restraints to resist wind and other notional horizontal loads.

This was then followed by a coordinated process between Farrat and BDP to finalise the design and layout of the core vertical and lateral isolation systems as well as the structural design of the pile caps and isolated raft slabs.

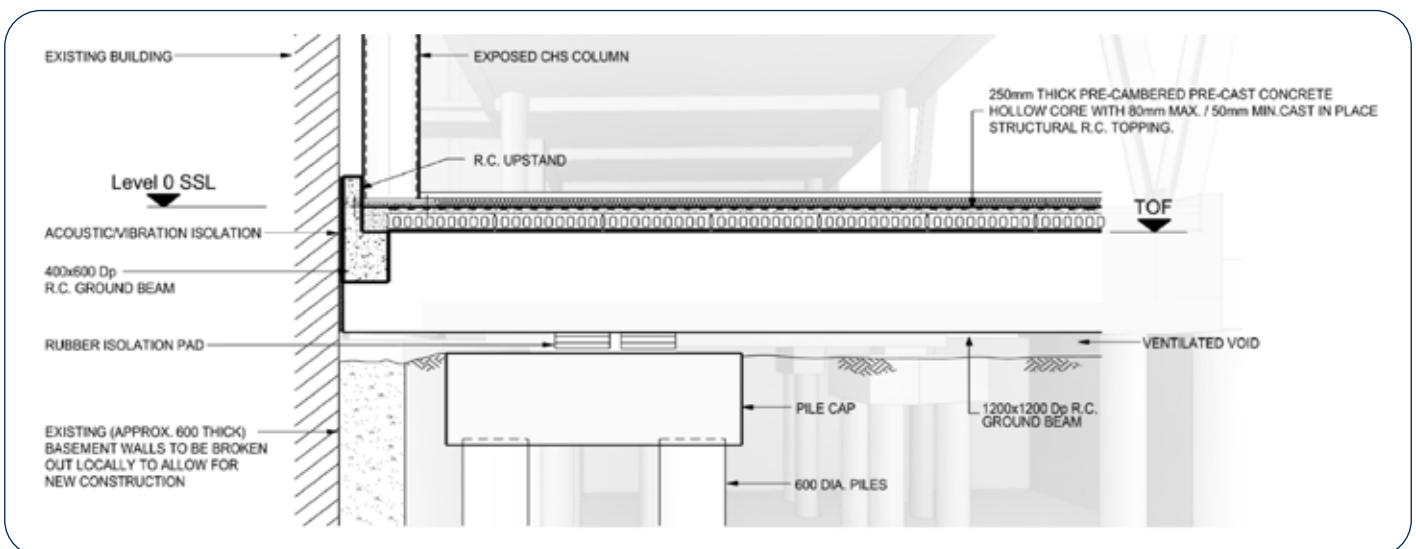

**Fig 10.2 Typical Section of the Building Isolation System and Foundations**

For the lift core, which was set at a lower level, where access was restricted once the upper isolated slab was cast, Farrat provided an ISOMAT Acoustic Floating Floor system to be constructed between the bearings to enable a flat slab to be cast where no access was feasible thereafter. The final stage of the process was for Farrat to provide BDP with all the bearing assembly dimensions and details for them to input into their foundation and structural drawings to ensure accurate setting out.

The majority of the subterranean outer perimeter of the building was in contact with existing, rigid structures either where ground beams were cast up against them or where the ground was backfilled up against it. In order to maintain the isolation performance of the building, Farrat's ISOFOAM perimeter isolation material was used as a resilient acoustic barrier.



A key principle of the entire design was to optimise the vibration isolation performance and make every detail easy and quick to construct with minimal risk.

**Oliver Farrell**  
**CEO & Technical Director,**  
**Structural Building Vibration Isolation Systems.**  
**Farrat Isolevel**



**Fig 10.3 The Lateral Restraint Bearing Assembly During Installation**  
 Care was taken throughout the grouting process to avoid air pockets within the grout bed.



**Fig 10.5 Farrat Natural Rubber Laminated Acoustic Bearing**  
 This is supporting and isolating the RC ground slab and the precast concrete ground floor slab.



**Fig 10.4 Farrat Natural Rubber Laminated Acoustic Bearing**  
 This is grouted in place with a galvanised levelling plate below and galvanised formwork plate above, ready for the RC ground beam formwork to be constructed around it.



**Fig 10.6 Bearing Assembly Supporting an External V Column**  
 Integrated lateral restraints withstand lateral forces from the V column as well as a 150 kN force from a potential vehicle impact.



In total, Farrat manufactured and supplied 113 Natural Rubber Laminated Acoustic Bearings, each with a natural frequency of 8 Hz at working loads.

Every bearing was designed, manufactured and tested up to full SLS load and in accordance with the applicable standard for building isolation bearings BS EN 1337-3 and a test certificate was issued for each bearing. Schedules were provided identifying which bearing, shear key or lateral restraint assembly was to be placed in each location.

Farrat supplied Galvanised Steel Levelling Plates and Upper Formwork Plates enabling the pile caps to be cast with a  $\pm 35$  mm tolerance. Once the bearings were in position they were grouted using a high-flow, non-shrink cementitious grout. The high-capacity lateral restraint shear keys were also installed in the cores in the same way.

This process enabled Bouygues to construct the bearing installation into the flowing construction process, working from one end of the building to another with pile caps still being cast at one end while at the other the precast ground floor was already being installed. Farrat visited the site once per week during the construction process to undertake detailed inspections as well as provide support and advice to the site team.



**Fig 10.7 50 mm Thick Farrat ISOFOAM IS12**

This was used to laterally separate the isolated building from any surrounding, non-isolated structures.

## Project Key Facts

- ▶ Total Building SLS Load: 129,400 kN
- ▶ 113 Natural Rubber Laminated Acoustic Bearings
- ▶ Natural frequency of 8 Hz at working loads
- ▶ Each bearing was tested upto full ULS loads
- ▶ Test Certificates issued for each bearing
- ▶ Installation schedule for each bearing, shear key and lateral restraint assembly

## Farrat also supplied 137 Structural Thermal Break Connection Plates

- ▶ For critical structural connections, between the top of the external V columns & underside of the 2nd floor structure



On the quality side, Farrat regularly came to site for reporting, which was instrumental in gaining the client's acceptance.

**Fabien Roca**  
Civil Works Manager  
Bouygues UK

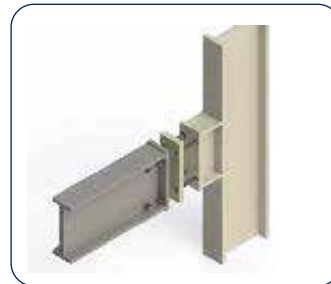

©WilkinsonEyre

# Case Study

## 10.2 Cartwright Gardens, London

**Client:** JP Dunn  
**Main Contractor:** BMCE  
**Architect:** TP Bennet + Engle  
**Consultant:** SRL Technical Servicesv

### Challenge

**Cartwright Gardens is a major redevelopment project in the prestigious Bloomsbury Conservation Area of central London delivering 954 modern student rooms in partnership with The University of London (UoL).**

Through the refurbishment of intercollegiate accommodation, the outstanding new scheme combines high-quality architectural design with extensive social facilities and public access to newly redesigned gardens.

The key challenge on this project was that the new design included keeping the existing building slab and sub structure. This presented a design problem as the site overlays part of the London Underground network producing disturbing vibrations that would require uniform deflection.

The south end of the building is built over Piccadilly Underground rail line with a third of the building requiring acoustic isolation. Proximity to the underground tunnel and problems with the soil strata below required a 500 - 650 mm reinforced concrete raft slab as the foundation design for the new building.



**Fig 10.8 Verlimber Isolation Mat During Installation**



**Fig 10.9 Isolation Detailing of Services**

## Solution

Farrat worked closely with the project Acoustic Consultants (SRL Technical Services) to develop a full-area isolation system based on Farrat's Verlimber VR27 material for this complex project.

The depth of the raft slab meant that loads from the building above were spread fairly evenly, presenting even pressure to the ground below, resulting in no concentrated load points to support with Acoustic Laminated Bearings. This high-performance polyurethane material had the ability to provide the necessary level of vibration isolation ( $f_n = 22\text{Hz}$ ) at a thickness of only 12.5mm. However, an additional 12.5 mm layer of Farrat Favim FV10 was also provided to protect the Verlimber from protrusions/imperfections in the blinding layer.

Farrat Verlimber VR27 was ideally suited to this project as it has a closed-cell structure meaning that its performance would not be affected if it got wet. It is also highly flexible, which allowed it to easily follow the unusual contours of the underside of the raft slab, as well as wrap around any protrusions or service penetrations.

Farrat delivered over 2,100 sheets of isolation material to this project, and were able to help the main contractor to manage the tight space on site by storing the material locally and making weekly drops as the installation progressed.

In addition to supplying the isolation material, Farrat provided a training and supervision service which involved training the main contractor's operatives to install the product and visiting the site regularly to check installed works.



Fig 10.10 Farrat Full-Area Isolation mat

## Project Key Facts

- ▶ Farrat provided over 2,100 sheets of isolation material including Farrat Verlimber and Farrat Favim
- ▶ 1,894 m<sup>2</sup> full-area mat Verlimber vibration Isolation (22 Hz)
- ▶ Overall contract value of approximately £235,000

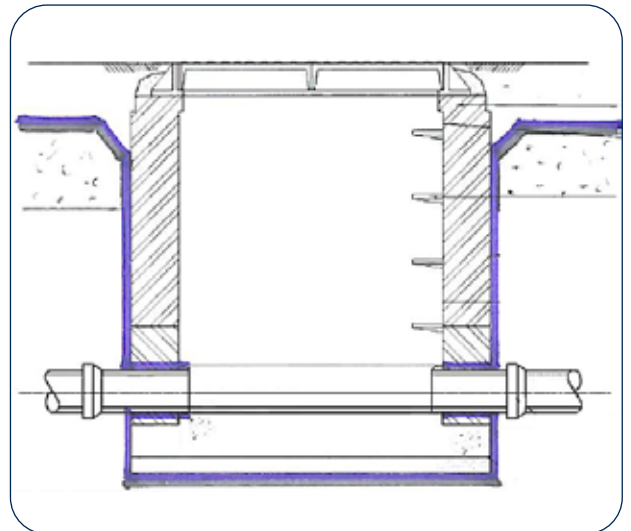

Fig 10.11 Isolation Detailing of Services

## Additional Farrat Solutions for Construction

### High-Performance Sound Insulation

Our superior range of sound insulation systems are used within a wide range of buildings to protect sensitive areas from noise sources, or to contain noise sources within their areas. Examples include, cinemas, concert halls & theatres, gyms & sports centres, residential buildings, offices & hotels, research facilities, music rooms and studios.

Products engineered by Farrat include ISOMAT, concrete and jack-up floating floors, timber frame isolation systems, steel frame isolation systems, partition isolation and a variety of acoustic washers.

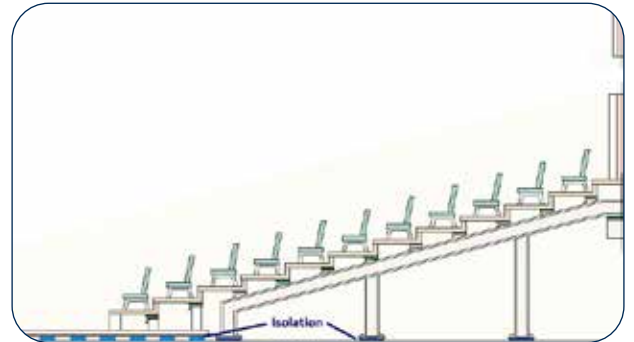

### Structural Thermal Break Connections

Farrat Structural Thermal Break Plates are high-performance thermal insulators used between horizontal and vertical connections of internal and external elements to prevent thermal or cold bridging.

Our structural thermal breaks provide a simple, economical and extremely effective solution to meeting Building Regulations by way of reducing heat loss and the risk of internal condensation. Our materials have British Board of Agreement (BBA) Certification, which is important in a market where there are materials offered which undergo no independent evaluation to ensure suitability in structural connections.

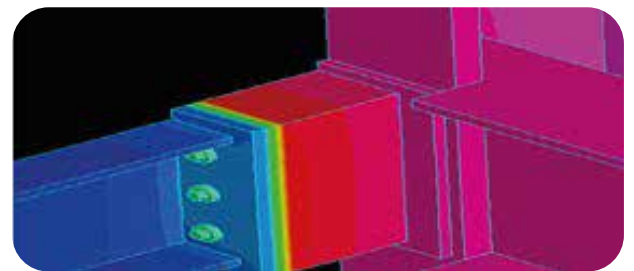

**View our full range online at:  
[www.farrat.com](http://www.farrat.com)**

Contact us:  
+44 (0) 161 924 1600  
[sales@farrat.com](mailto:sales@farrat.com)  
[www.farrat.com](http://www.farrat.com)